



## KTM SERIES EB OM-2 SPLIT BODY FLOATING BALL VALVES

OMNI-II, a new generation of ball valves with LOW-E fugitive emission certification, cavity relieving seats and ease of automation



### FEATURES

- Designed to ASME B16.34, API 608, API 6D and ISO 171292.
- Bidirectional shut-off.
- Superior valve design at a competitive price.
- Fugitive emissions control for flammable and non-flammable applications.
- Valve fugitive emissions capability third party certified to ISO 15848-1.
- Machined ISO actuator mounting pad.
- Pure white E-seat (PTFE/PFA copolymer) seal relieves concern over product contamination.
- Positive alignment of split body.
- Fire test certified to API 607 5th edition and ISO 10497.
- PTFE bearing and packing rings reduce wear.
- Lower operating torque for ease of operation and reduced actuator cost.
- Positive position indication.
- Blowout-proof shaft.
- NACE MR0175 / ISO 15146 available on request.
- Locking device is available.
- Static electricity grounding device.
- Manufactured under ISO 9001 certified quality system.
- CE marking PED 97/23/EC as standard.
- Various seat types are available.

In addition to standard E-seat, various seats are available in following variety. Each seat option will meet a wide range of performance, suitable for many applications.

- PTFE/PFA copolymer
- E-seat as standard\*
- PEEK seat (option)
- Grati<sup>®</sup> seat (option)
- Metallite<sup>®</sup> seat (option)

\* Please refer to the Pressure/Temperature rating

### GENERAL APPLICATIONS

Chemical, petrochemical, pulp and paper, reactive monomers, oil and gas production, steam, hot gases, toxic and lethal, fire-safe and flammables

#### Option

- Shaft extension
- For cryogenic, oxygen and vacuum services
- Special painting
- Special tests
  - X-ray (RT)
  - Liquid penetrant (PT)
  - Positive Material Identification (PMI)

### TECHNICAL DATA

Model/sizes:	Full bore EB1 DN 15 to DN 200 (NPS ½ to NPS 8) Reduced bore EB2 DN 150 to DN 250 (NPS 6 to NPS 10)
Pressure rating:	ASME Class 150, 300 JIS 10K, 20K (JPI also available)
Temperature:	-29°C to 270°C (-20°F to 518°F) (Depending on options -196°C to 500°C [-320°F to 932°F] is available)
Seat leakage:	Zero leakage [E-seat] to ISO 5208 Rate A and API 598

# KTM SERIES EB OM-2 SPLIT BODY FLOATING BALL VALVES

**ISO 5211 ACTUATOR MOUNTING PAD:**  
Machined 'automation pad' allows precise mounting of actuator; mounting bolts independent from shaft-packing gland bolts. Exact alignment reduces torque requirements and prevents out-of-line wear.

**RADIAL THRUST BEARINGS:**  
Radial loading absorbed and friction from axial shaft loading reduced. Dual thrust bearings support shaft for extended cycle life and superior thermal characteristics.

**BLOW-OUT PROOF SHAFT AND PRIMARY SHAFT SEAL:**  
Shaft shoulder is integral part of shaft, retained internally to prevent shaft blowout from pressure in body cavity. Primary shaft seal prevents leakage to atmosphere, also serves as low-torque bearing.

**PRECISE, SMOOTH BALL:**  
Ball sphericity and surface finish are key factors in attaining long valve life, low operating torque and superb pressure-holding capacity. Vented ball optional.

**RIGID SPLIT BODY:**  
Designed with extra bolts to assure positive alignment and maximum protection against bending stresses in the piping and forces produced by thermal distortion; designed with secondary metal to metal seal in the event of fire.

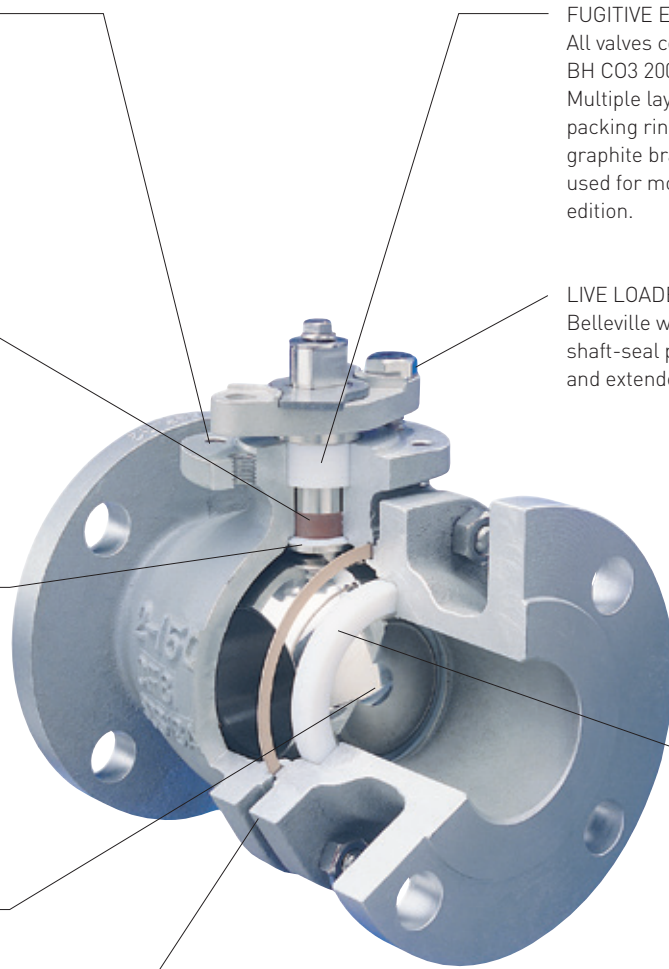

**FUGITIVE EMISSIONS CONTROL:**  
All valves certified to ISO 15848-1 Class BH C03 200°C (392°F), as standard. Multiple layers of adjustable PTFE chevron packing rings for standard models; while graphite braided / die-formed seals are used for models tested to API 607 5th edition.

**LIVE LOADED SPRING:**  
Belleville washer keeps constant force on shaft-seal packing, ensuring seal integrity and extended valve life.

**CAVITY RELIEVING SEATS:**  
As standard in the closed position, with E-seat, soft seat as standard.

**CAST BLEED-PORT BOSS:**  
Provision can be made for drain bleed port when required. (Not shown)

**ANTI-STATIC GROUNDING:**  
Special retaining spring provides positive ground for use with volatile or flammable liquids is standard. (Not shown)

# KTM SERIES EB 0M-2 SPLIT BODY FLOATING BALL VALVES

## STANDARD PRIMARY CONTAINMENT SEALS FOR FUGITIVE EMISSION CONTROL

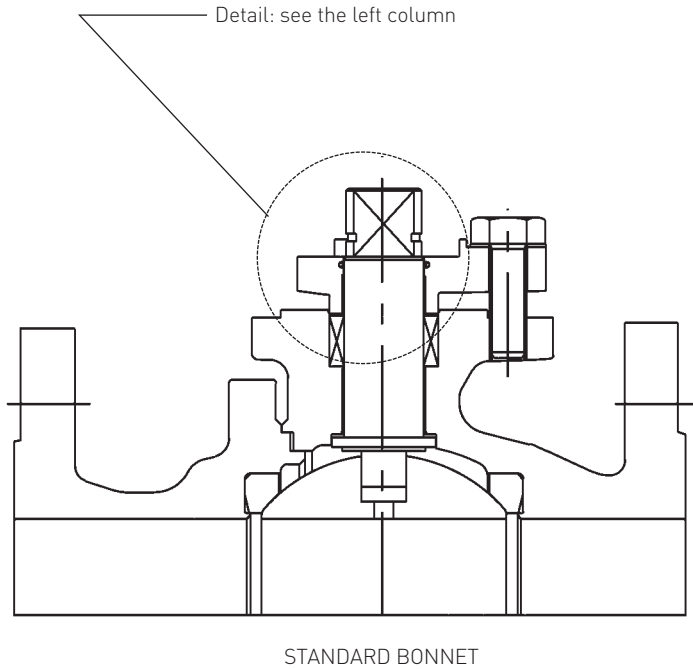

### STANDARD SEALS

Superior quality multi-layered, adjustable chevron packing rings as shaft seals.

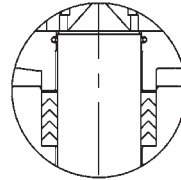

### FIRE TESTED (OPTION)

Die-formed carbon fiber seals, sandwiched by braided graphite rings. Fire safe in design, minimizing leakage in the event of fire. Fire tested to API 607 5th edition.

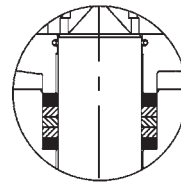

## OPTIONAL SECONDARY CONTAINMENT SEALS FOR FUGITIVE EMISSION CONTROL / TOXIC AND LETHAL APPLICATIONS

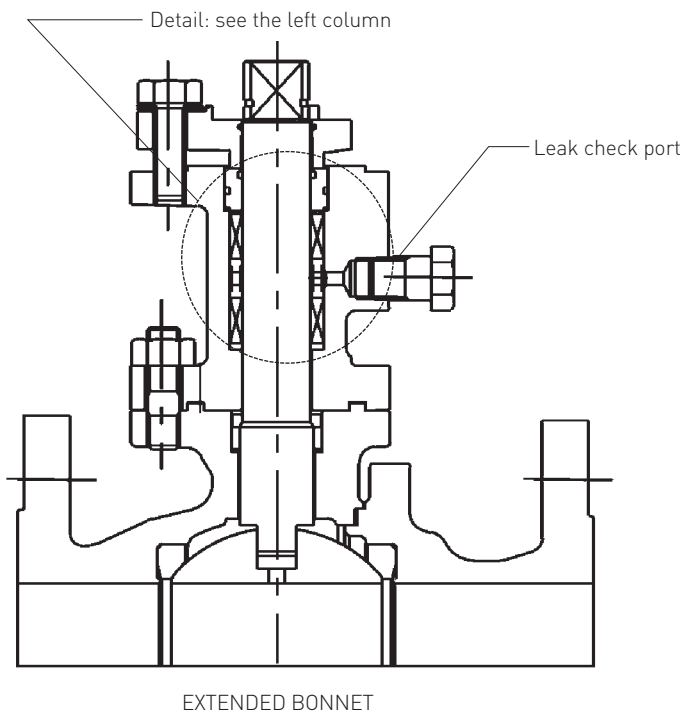

### CHEVRON PTFE PACKING (OPTION)

Double packing gland elastomer seal with a lantern ring. If media leaks through primary seal, it can be detected and stopped by pressure injection.

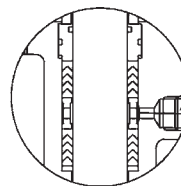

### FLAMMABLE SERVICES (OPTION)

Double packing gland graphite seal and lantern ring.

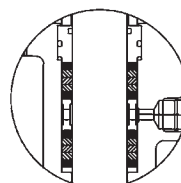

# KTM SERIES EB OM-2 SPLIT BODY FLOATING BALL VALVES



PHOTO (A)

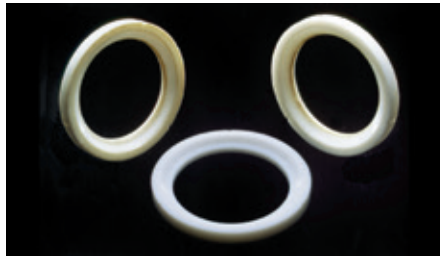

PHOTO (B)

The OM-2 is available in three basic types of seats: soft, Gratite® and Metaltite®. Each offering a range of performance suitable for many applications.

## SUPERIOR SOFT SEAT PERFORMANCE

Choose from two soft seat materials: the standard E-seat PTFE/PFA copolymer or PEEK. Each type of seat is retained in the same manner and is machined with a protective lip, designed to eliminate seat deformation and cold flow. This same lip acts as a secondary back-up seal, which forms a metal to metal contact in the event the primary soft seal is burnt in a fire (see details, right).

The E-seat offers process purity, strength, integrity, low permeability and high resiliency. It is composed of a unique molecularly enhanced copolymer of PTFE and PFA. It offers a full range of properties formerly requiring two separate materials. The E-seat provides pressure and temperature capabilities previously available only with glass or carbon fiber-reinforced PTFE. In high-temperature operations, the seat remains white, eliminating the problem of color contamination associated with seats made from darker reinforced materials. The E-seat is excellent on a wide variety of applications but is particularly recommended for use on styrene and butadiene, where low permeability is a required performance factor; and on low-pressure steam, where flaking of virgin PTFE is a problem. It is also recommended for use on food and beverage, pharmaceutical and biotech, paper, clean gas and any other applications where product purity and the lack of foreign fillers are critical to process media integrity.

The Popcorn Factor: the photo (A) shows a virgin PTFE seat after the attack by a reactive monomer (in this case, styrene). The material's molecular matrix was penetrated by the vapor pressure of the uninhibited monomers, resulting in a polymeric reaction, commonly known as 'popcorn polymerization'. This reaction can totally destroy the seat material.

The photo (B) shows the results of the E-seat copolymer tested by Emerson. Using butadiene, generally considered the worst-case scenario due to its small molecular size, the test ran for two years at 0.84 MPa (122 psi) and 82°C (180°F). The seats experienced minimum distortion and, after the two-year period, did not leak in service. Pressure tests after removal, at 1.1 times of design pressure, also showed no leakage. The photo shows two of the tested seats and a new seat in the middle for comparison.

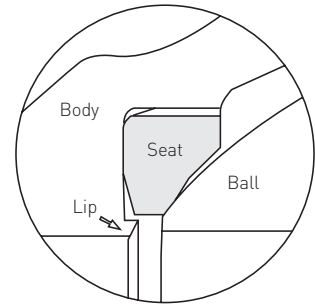

ANTI COLD FLOW FEATURE

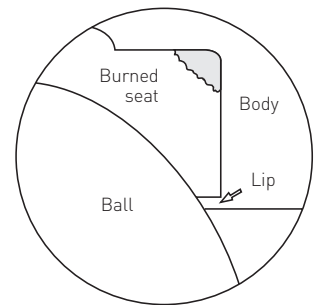

SECONDARY BACK UP SEAL

# KTM SERIES EB OM-2 SPLIT BODY FLOATING BALL VALVES

## GRATITE® SEAT

A proprietary product for high-temperature, high-pressure, flammable and corrosive critical-process applications, the Gratite® seat offers superior performance and reliability. Gratite® is a bonded composite of hard graphite material. The cushion seal provides resiliency during thermal expansion-contraction. The result is a seat with physical properties that are far superior to conventional ball valve seats of carbon graphite construction.

- More economical than Stellite
- High resistance to thermal shock

Gratite® is a registered trademark of Emerson Japan Co., LTD. For more information, refer to technical data sheet VCTDS-02582.

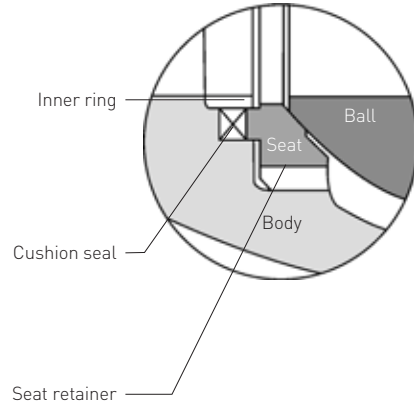

## METALTITE® SEAT

Emerson utilizes proprietary processes with special lapping technologies to provide a higher-quality product with a superior level of performance. Suitable for temperature range up to 500°C (932°F), the Metaltite® metal seat provides high performance solutions to many difficult and bidirectional applications. Precision lapping of the ball-to-seat fit result in superior interfacing and a tight shut-off conforming to FCI 70-2 Class V and Class VI (option). Available with two different ball coatings: Hard chrome or nickel alloy overlay. Durable stellite stainless seats are highly corrosion and erosion resistant. PTFE or soft carbon shaft seals are available.

Metaltite® is a registered trademark of Emerson Japan Co., LTD. For more information, refer to technical data sheet VCTDS-02565.

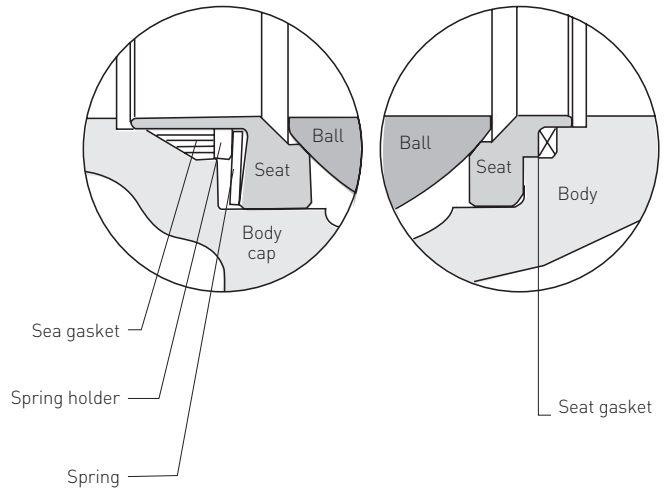

# KTM SERIES EB OM-2 SPLIT BODY FLOATING BALL VALVES

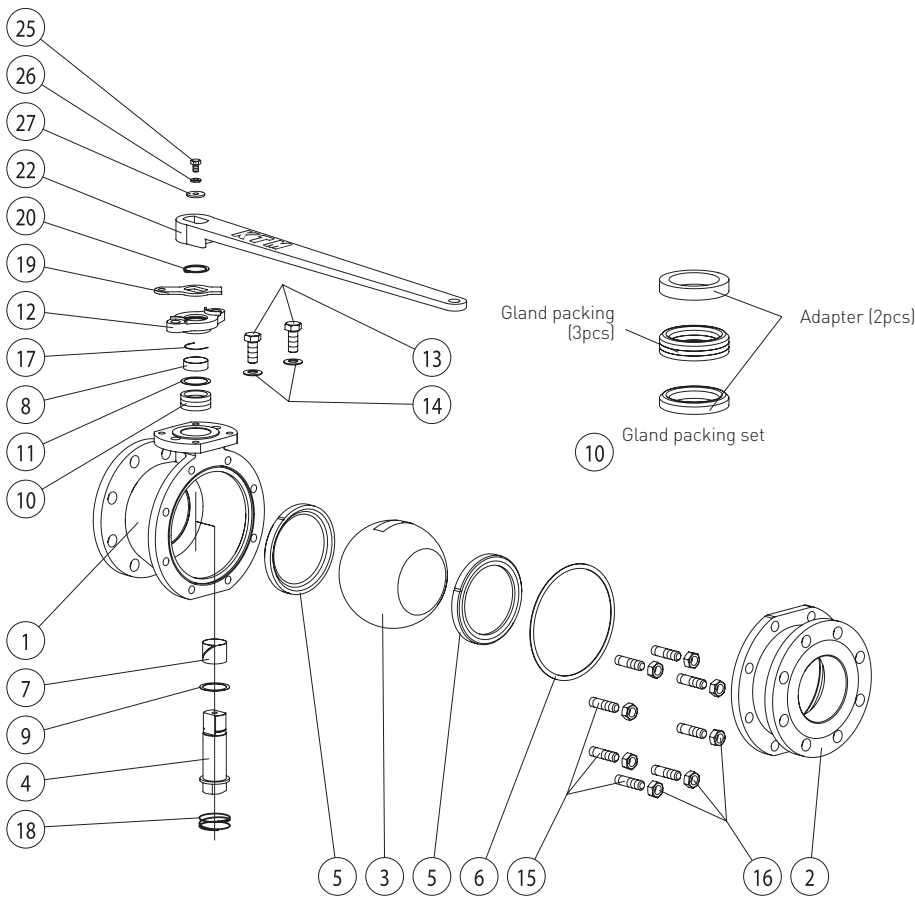

## STANDARDS

Design:	ASME B16.34
Face to face:	ASME B16.10, JIS B2002
End connection:	ASME B16.5, JIS B2220
Testing:	ASME B16.34, API 598, API 6D
Fire test:	API 607 5th edition
Quality assurance:	ISO 9001

## PARTS LIST AND MATERIALS OF CONSTRUCTION MATERIALS

No.	Parts name	Materials			Qty
		Carbon steel	304 Stainless steel	316 Stainless steel	
1	Body	WCB	CF8	CF8M	1
2	Body cap	WCB	CF8	CF8M	1
3	Ball	CF8	CF8	CF8M	1
4	Shaft	A276 (TP) 304	A276 (TP) 304	A276 (TP) 316	1
5	Seat	PTFE / PFA copolymer	PTFE / PFA copolymer	PTFE / PFA copolymer	2
6	Gasket	R-PTFE	R-PTFE	R-PTFE	1
7	Shaft bearing	R-PTFE	R-PTFE	R-PTFE	1
8	Shaft bearing	PTFE	PTFE	PTFE	1
9	Thrust bearing	PTFE	PTFE	PTFE	1
10	Gland packing set	PTFE	PTFE	PTFE	1 set
11	Packing washer	316SS	316SS	316SS	1
12	Gland flange	CF8	CF8	CF8	1
13	Gland bolt	A193 (G) B8	A193 (G) B8	A193 (G) B8	2
14	Live loading spring	SUS304	SUS304	SUS304	2
15	Stud	A193 (G) B7	A193 (G) B8	A194 (G) 8	4-12
16	Nut	A194 (G) 2H	A193 (G) B8	A194 (G) 8	4-12
17	Spring	316SS	316SS	316SS	1
18	Spring [DN 65 and larger]	316SS	316SS	316SS	1
19	Stopper	304SS	304SS	304SS	1
20	Snap ring [C-type]	304SS	304SS	304SS	1
22	Handle	SS400Zn / FCD450	SS400Zn / FCD450	SS400Zn / FCD450	1
25	Hexagon bolt	304SS	304SS	304SS	1
26	Spring washer	304SS	304SS	304SS	1
27	Plate washer	304SS	304SS	304SS	1

The material parts vary slightly depending on the valve size, but the basic structures are identical. Other materials are also available. Please consult for the details.

# KTM SERIES EB OM-2 SPLIT BODY FLOATING BALL VALVES

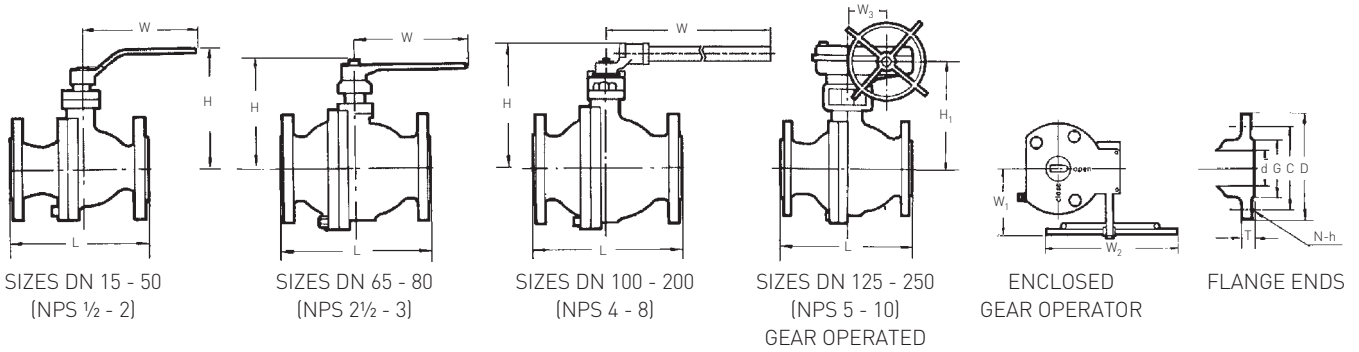

## ASME CLASS 150 / JIS 10K DIMENSIONS (mm)

Valve size (DN)	EB11 Full bore								Weight (kg)	EB21 Reduced bore								Weight (kg)	JIS 10K Flange dimensions					
	Bore (d)	L	H	H1	W	W <sub>1</sub>	W <sub>2</sub>	W <sub>3</sub>		Ball bore (d <sub>1</sub> )	L	H	H1	W	W <sub>1</sub>	W <sub>2</sub>	W <sub>3</sub>		D	C	G	T	N	h
15	13	108	81	-	130	-	-	-	2.3	-	-	-	-	-	-	-	-	95	70	51	12	4	15	
20	19	117	85	-	130	-	-	-	3.0	-	-	-	-	-	-	-	-	100	75	56	14	4	15	
25	25	127	98	-	160	-	-	-	4.6	-	-	-	-	-	-	-	-	125	90	67	14	4	19	
40	38	165	124	-	230	-	-	-	7.8	-	-	-	-	-	-	-	-	140	105	81	16	4	19	
50	51	178	135	-	230	-	-	-	11.0	-	-	-	-	-	-	-	-	155	120	96	16	4	19	
65	64	190	165	-	400	-	-	-	20.0	-	-	-	-	-	-	-	-	175	140	116	18	4	19	
80	76	203	174	-	400	-	-	-	24.0	-	-	-	-	-	-	-	-	185	150	126	18	8	19	
100	102	229	240	-	715	-	-	-	34.0	-	-	-	-	-	-	-	-	210	175	151	18	8	19	
125	127	356	310	312	1140	85	450	240	50.0	-	-	-	-	-	-	-	-	250	210	182	20	8	23	
150	152	394	330	332	1140	85	450	240	69.0	127	267	310	312	1140	85	450	240	55	280	240	212	22	8	23
200	203	457	405	415	1510	116	600	350	108.0	152	292	330	332	1140	85	450	240	83	330	290	262	22	12	23
250	-	-	-	-	-	-	-	-	-	203	330	405	415	1510	116	600	350	122	400	355	324	24	12	25

## ASME CLASS 150 / JIS 10K DIMENSIONS (inch)

Valve size (NPS)	EB11 Full bore								Weight (lbs)	EB21 Reduced bore								Weight (lbs)	JIS 10K Flange dimensions					
	Bore (d)	L	H	H1	W	W <sub>1</sub>	W <sub>2</sub>	W <sub>3</sub>		Ball bore (d <sub>1</sub> )	L	H	H1	W	W <sub>1</sub>	W <sub>2</sub>	W <sub>3</sub>		D	C	G	T	N	h
1/2	0.50	4.3	3.2	-	5.1	-	-	-	5.1	-	-	-	-	-	-	-	-	3.7	2.8	2.0	0.5	0.2	0.6	
3/4	0.75	4.6	3.3	-	5.1	-	-	-	6.6	-	-	-	-	-	-	-	-	3.9	3.0	2.2	0.6	0.2	0.6	
1	1.00	5.0	3.9	-	6.3	-	-	-	10.1	-	-	-	-	-	-	-	-	4.9	3.5	2.6	0.6	0.2	0.7	
1 1/2	1.50	6.5	4.9	-	9.1	-	-	-	17.2	-	-	-	-	-	-	-	-	5.5	4.1	3.2	0.6	0.2	0.7	
2	2.00	7.0	5.3	-	9.1	-	-	-	24.2	-	-	-	-	-	-	-	-	6.1	4.7	3.8	0.6	0.2	0.7	
2 1/2	2.50	7.5	6.5	-	15.7	-	-	-	44.0	-	-	-	-	-	-	-	-	6.9	5.5	4.6	0.7	0.2	0.7	
3	3.00	8.0	6.9	-	15.7	-	-	-	52.8	-	-	-	-	-	-	-	-	7.3	5.9	5.0	0.7	0.3	0.7	
4	4.00	9.0	9.4	-	28.1	-	-	-	74.8	-	-	-	-	-	-	-	-	8.3	6.9	5.9	0.7	0.3	0.7	
5	5.00	14.0	12.2	312	44.9	3.3	17.7	9.4	110.0	-	-	-	-	-	-	-	-	9.8	8.3	7.2	0.8	0.3	0.9	
6	6.00	15.5	13.0	332	44.9	3.3	17.7	9.4	151.8	5.00	10.5	12.2	12.3	44.9	3.3	17.7	9.4	121.0	11.0	9.4	8.3	0.9	0.3	0.9
8	8.00	18.0	15.9	415	59.4	4.6	23.6	13.8	237.6	6.00	11.5	13.0	13.1	44.9	3.3	17.7	9.4	182.6	13.0	11.4	10.3	0.9	0.5	0.9
10	-	-	-	-	-	-	-	-	-	8.00	13.0	15.9	16.3	59.4	4.6	23.6	13.8	268.4	15.7	14.0	12.8	0.9	0.5	1.0

### NOTES

- Weights for DN 150, 200, and 250 (NPS 6, 8, and 10) indicate lever operator.
- For gear operated, add 14 kg (31 lbs) for DN 150 (NPS 6) (reduced bore DN 200 (NPS 8)) and 35 kg (77 lbs) for DN 200 (NPS 8) (reduced bore DN 250 (NPS 10)).
- Face to face dimensions for EB21 size DN 150 - 250 (NPS 6 - 10) and EB22 size DN 200 and 250 (NPS 8 and 10) are complied with ASME B16.10 short pattern.

- D: Outside diameter
- C: Bolt circle diameter
- G: Raised face diameter
- T: Flange thickness
- N: Number of bolts
- h: Bolt hole size
- d: Bore diameter
- d1: Ball bore

# KTM SERIES EB OM-2 SPLIT BODY FLOATING BALL VALVES

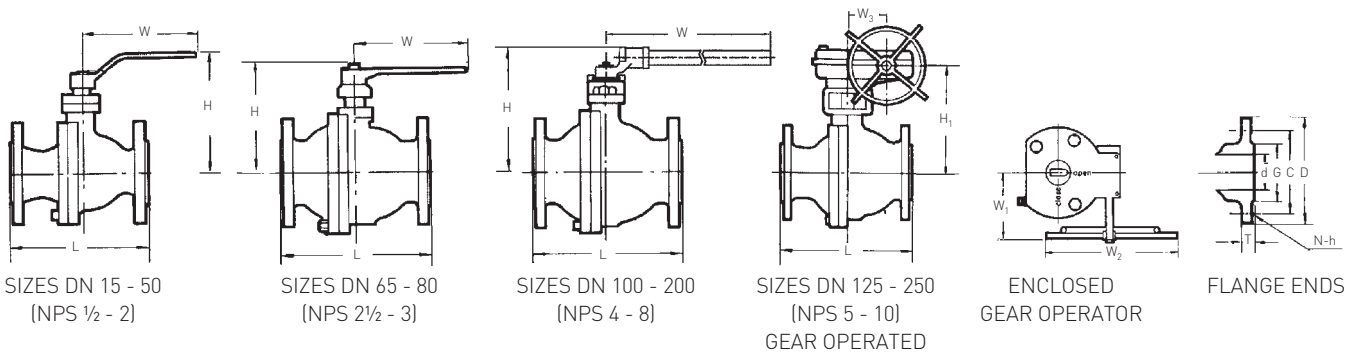

## ASME CLASS 300 / JIS 20K DIMENSIONS (mm)

Valve size (DN)	EB12 Full bore								Weight (kg)	EB22 Reduced bore								Weight (kg)	JIS 20K Flange dimensions					
	Bore (d)	L	H	H1	W	W <sub>1</sub>	W <sub>2</sub>	W <sub>3</sub>		Ball bore (d <sub>1</sub> )	L	H	H1	W	W <sub>1</sub>	W <sub>2</sub>	W <sub>3</sub>		D	C	G	T	N	h
15	13	140	81	-	130	-	-	-	2.5	-	-	-	-	-	-	-	-	95	70	51	14	4	15	
20	19	152	85	-	130	-	-	-	3.2	-	-	-	-	-	-	-	-	100	75	56	16	4	15	
25	25	165	98	-	160	-	-	-	5.0	-	-	-	-	-	-	-	-	125	90	67	16	4	19	
40	38	190	124	-	230	-	-	-	11.0	-	-	-	-	-	-	-	-	140	105	81	18	4	19	
50	51	216	135	-	230	-	-	-	15.0	-	-	-	-	-	-	-	-	155	120	96	18	8	19	
65	64	241	165	-	400	-	-	-	24.0	-	-	-	-	-	-	-	-	175	140	116	20	8	19	
80	76	283	174	-	400	-	-	-	36.0	-	-	-	-	-	-	-	-	200	160	132	22	8	23	
100	102	305	240	-	650	-	-	-	42.0	-	-	-	-	-	-	-	-	225	185	160	24	8	23	
125	127	381	310	312	1140	85	450	240	60.0	-	-	-	-	-	-	-	-	270	225	195	26	8	25	
150	152	403	330	332	1140	85	450	240	106.0	127	403	310	312	1140	85	450	240	67	305	260	230	28	12	25
200	203	502	405	415	1410	116	600	350	122.0	152	419	330	332	1140	85	450	240	95	350	305	275	30	12	25
250	-	-	-	-	-	-	-	-	-	203	457	405	415	1510	116	600	350	144	430	380	345	34	12	27

## ASME CLASS 300 / JIS 20K DIMENSIONS (inch)

Valve size (NPS)	EB12 Full bore								Weight (lbs)	EB22 Reduced bore								Weight (lbs)	JIS 20K Flange dimensions					
	Bore (d)	L	H	H1	W	W <sub>1</sub>	W <sub>2</sub>	W <sub>3</sub>		Ball bore (d <sub>1</sub> )	L	H	H1	W	W <sub>1</sub>	W <sub>2</sub>	W <sub>3</sub>		D	C	G	T	N	h
1/2	0.50	5.5	3.2	-	5.1	-	-	-	5.5	-	-	-	-	-	-	-	-	3.7	2.8	2.0	0.6	0.2	0.6	
3/4	0.75	6.0	3.3	-	5.1	-	-	-	7.0	-	-	-	-	-	-	-	-	3.9	3.0	2.2	0.6	0.2	0.6	
1	1.00	6.5	3.9	-	6.3	-	-	-	11.0	-	-	-	-	-	-	-	-	4.9	3.5	2.6	0.6	0.2	0.7	
1 1/2	1.50	7.5	4.9	-	9.1	-	-	-	24.2	-	-	-	-	-	-	-	-	5.5	4.1	3.2	0.7	0.2	0.7	
2	2.00	8.5	5.3	-	9.1	-	-	-	33.0	-	-	-	-	-	-	-	-	6.1	4.7	3.8	0.7	0.3	0.7	
2 1/2	2.50	9.5	6.5	-	15.7	-	-	-	52.8	-	-	-	-	-	-	-	-	6.9	5.5	4.6	0.8	0.3	0.7	
3	3.00	11.1	6.9	-	15.7	-	-	-	79.2	-	-	-	-	-	-	-	-	7.9	6.3	5.2	0.9	0.3	0.9	
4	4.00	12.0	9.4	-	25.6	-	-	-	92.4	-	-	-	-	-	-	-	-	8.9	7.3	6.3	0.9	0.3	0.9	
5	5.00	15.0	12.2	12.3	44.9	3.3	17.7	9.4	132.0	-	-	-	-	-	-	-	-	10.6	8.9	7.7	1.0	0.3	1.0	
6	6.00	15.9	13.0	13.1	44.9	3.3	17.7	9.4	233.2	5.00	15.9	12.2	12.3	44.9	3.3	17.7	9.4	147.4	12.0	10.2	9.1	1.1	0.5	1.0
8	8.00	19.8	15.9	16.3	55.5	4.6	23.6	13.8	268.4	6.00	16.5	13.0	13.1	44.9	3.3	17.7	9.4	209.0	13.8	12.0	10.8	1.2	0.5	1.0
10	-	-	-	-	-	-	-	-	-	8.00	18.0	15.9	16.3	59.4	4.6	23.6	13.8	316.8	16.9	15.0	13.6	1.3	0.5	1.1

### NOTES

- Weights for DN 150, 200, and 250 (NPS 6, 8, and 10) indicate lever operator.
- For gear operated, add 14 kg (31 lbs) for DN 150 (NPS 6) (reduced bore DN 200 (NPS 8)) and 35 kg (77 lbs) for DN 200 (NPS 8) (reduced bore DN 250 (NPS 10)).
- Face to face dimensions for EB21 size DN 150 - 250 (NPS 6 - 10) and EB22 size DN 200 and 250 (NPS 8 and 10) are complied with ASME B16.10 short pattern.

- D: Outside diameter
- C: Bolt circle diameter
- G: Raised face diameter
- T: Flange thickness
- N: Number of bolts
- h: Bolt hole size
- d: Bore diameter
- d1: Ball bore



# KTM SERIES EB OM-2 SPLIT BODY FLOATING BALL VALVES

## FLANGE ENDS

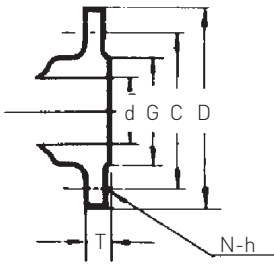

- D: Outside diameter
- C: Bolt circle diameter
- G: Raised face diameter
- T: Flange thickness
- N: Number of bolts
- h: Bolt hole size
- d: Bore diameter
- d1: Ball bore

## FLANGE DIMENSIONS (mm)

Valve size (DN)	ASME Class 150						ASME Class 300					
	D	C	G	T*	N	h	D	C	G	T*	N	h
15	89	60.5	35	11.2	4	16	95	66.5	35	14.3	4	16
20	98	70.0	43	11.2	4	16	117	82.5	43	15.9	4	19
25	108	79.5	51	11.2	4	16	124	89.0	51	17.5	4	19
40	127	98.5	73	14.3	4	16	156	114.5	73	20.7	4	22
50	152	120.5	92	15.9	4	19	165	127.0	92	22.3	8	19
65	178	139.5	105	17.5	4	19	190	149.0	105	25.4	8	22
80	190	152.5	127	19.1	4	19	210	168.0	127	28.6	8	22
100	229	190.5	157	23.9	8	19	254	200.0	157	31.8	8	22
125	254	216.0	186	23.9	8	22	279	235.0	186	35.0	8	22
150	279	241.5	216	25.4	8	22	318	270.0	216	36.6	12	22
200	343	298.5	270	28.6	8	22	381	330.0	270	41.3	12	25
250	406	362.0	324	30.2	12	25	444	387.5	324	47.7	16	29

\*RF : 1.6 mm height

## K<sub>v</sub> VALUES

Valve size (DN)	Full bore	Reduced bore
15	26	-
20	50	-
25	94	-
40	260	-
50	480	-
65	750	-
80	1300	-
100	2300	-
125	3800	-
150	5400	1800
200	10000	2500
250	-	4500

## FLANGE DIMENSIONS (inch)

Valve size (NPS)	ASME Class 150						ASME Class 300					
	D	C	G	T*	N	h	D	C	G	T*	N	h
1/2	3.5	2.4	1.4	0.4	0.2	0.6	3.7	2.6	1.4	0.6	0.2	0.6
3/4	3.9	2.8	1.7	0.4	0.2	0.6	4.6	3.2	1.7	0.6	0.2	0.7
1	4.3	3.1	2.0	0.4	0.2	0.6	4.9	3.5	2.0	0.7	0.2	0.7
1 1/2	5.0	3.9	2.9	0.6	0.2	0.6	6.1	4.5	2.9	0.8	0.2	0.9
2	6.0	4.7	3.6	0.6	0.2	0.7	6.5	5.0	3.6	0.9	0.3	0.7
2 1/2	7.0	5.5	4.1	0.7	0.2	0.7	7.5	5.9	4.1	1.0	0.3	0.9
3	7.5	6.0	5.0	0.8	0.2	0.7	8.3	6.6	5.0	1.1	0.3	0.9
4	9.0	7.5	6.2	0.9	0.3	0.7	10.0	7.9	6.2	1.3	0.3	0.9
5	10.0	8.5	7.3	0.9	0.3	0.9	11.0	9.3	7.3	1.4	0.3	0.9
6	11.0	9.5	8.5	1.0	0.3	0.9	12.5	10.6	8.5	1.4	0.5	0.9
8	13.5	11.8	10.6	1.1	0.3	0.9	15.0	13.0	10.6	1.6	0.5	1.0
10	16.0	14.3	12.8	1.2	0.5	1.0	17.5	15.3	12.8	1.9	0.6	1.1

\*RF : 0.06 inch height

## C<sub>v</sub> VALUES

Valve size (NPS)	Full bore	Reduced bore
1/2	30	-
3/4	58	-
1	109	-
1 1/2	301	-
2	555	-
2 1/2	867	-
3	1503	-
4	2659	-
5	4393	-
6	6242	2081
8	11560	2890
10	-	5202

# KTM SERIES EB OM-2 SPLIT BODY FLOATING BALL VALVES

## METRIC SYSTEM

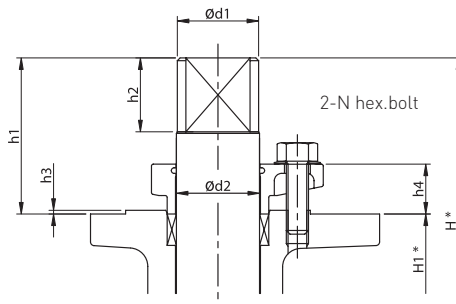
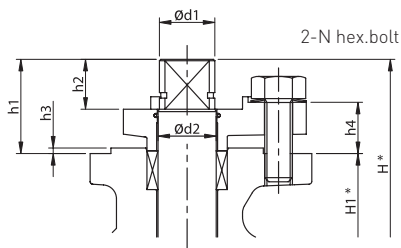
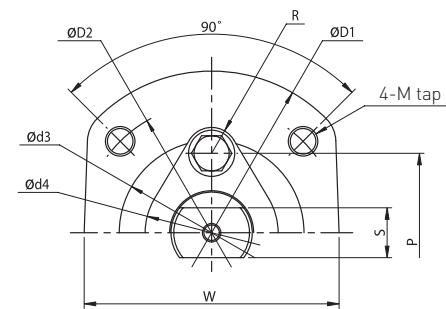
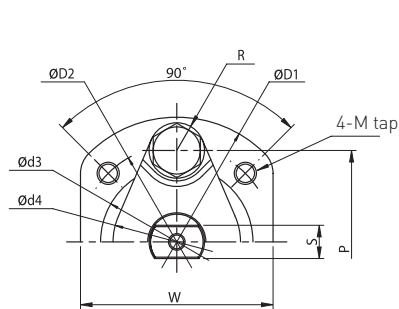

SIZES DN 15 TO DN 100

SIZES DN 125 TO DN 250

\* H and H<sub>1</sub> are from valve center

### TORQUE (Nm)

Size (DN)	Differential pressure (MPa)					
	0	1	2	3	4	5
15	5.5	5.5	5.5	5.6	5.8	6.6
20	7.0	7.0	7.1	7.2	7.6	8.5
25	9.0	9.0	9.4	10.0	10.5	12.0
40	15.5	16.0	17.0	17.5	20.0	25.0
50	22.0	22.5	24.0	27.0	32.0	40.0
65	40.0	41.0	45.0	51.0	60.5	70.0
80	60.0	69.0	78.0	89.0	100.0	115.0
100	110.0	125.0	145.0	160.0	185.0	210.0
125	200.0	230.0	265.0	310.0	350.0	380.0
150	310.0	380.0	450.0	540.0	580.0	620.0
200	500.0	720.0	960.0	1220.0	1450.0	1600.0

E-seat / PTFE gland packing

### NOTE

Above-mentioned torque table's value does not contain the safety rate.

When you select the actuator, please multiply the safety rate corresponding to the necessity.

### GLAND DIMENSIONS (mm)

Valve size (DN)		d <sub>1</sub>		d <sub>2</sub>		d <sub>3</sub>		S															
Full bore	Reduced bore	Max.	Min.	Max.	Min.	Max.	Min.	d <sub>4</sub>	D <sub>1</sub>	D <sub>2</sub>	h <sub>1</sub>	h <sub>2</sub>	h <sub>3</sub>	h <sub>4</sub>	H	H <sub>1</sub>	M	N	P	R	Max.	Min.	W
15	-	9.95	9.85	11.00	10.96	30.00	29.90	28	55	42	22.0	11	2	14.0	59.0	37	M6	M6	40	6	6.93	6.88	42.7
20	-	9.95	9.85	11.00	10.96	30.00	29.90	28	55	42	22.0	11	2	14.0	63.0	41	M6	M6	40	6	6.93	6.88	42.7
25	-	13.95	13.85	15.00	14.96	35.00	34.91	33	65	50	26.5	14	2	15.5	75.5	49	M6	M8	48	8	7.92	7.86	50.4
40	-	19.95	19.85	21.00	20.95	55.00	54.90	46	90	70	33.5	18	2	18.5	102.5	69	M8	M10	66	10	11.91	11.84	70.0
50	-	19.95	19.85	21.00	20.95	55.00	54.90	46	90	70	33.5	18	2	18.5	112.5	79	M8	M10	66	10	11.91	11.84	70.0
65	-	26.95	26.85	28.00	27.95	70.00	69.88	66	125	102	50.5	31	2	22.0	154.5	104	M10	M14	86	13	16.91	16.84	100.0
80	-	26.95	26.85	28.00	27.95	70.00	69.88	66	125	102	50.5	31	2	22.0	163.5	113	M10	M14	86	13	16.91	16.84	100.0
100	-	33.95	33.85	35.00	34.94	70.00	69.88	66	125	102	50.5	31	2	22.0	189.0	138	M10	M14	86	13	21.90	21.81	100.0
125	150	43.95	43.85	45.00	44.94	100.00	99.86	72	175	140	84.5	40	2	27.0	252.0	168	M16	M12	86	14	26.90	26.81	138.0
150	200	43.95	43.85	45.00	44.94	100.00	99.86	72	175	140	84.5	40	2	27.0	272.5	188	M16	M12	86	14	26.90	26.81	138.0
200	250	52.95	52.85	54.00	53.93	130.00	129.84	90	210	165	107.0	53	2	33.0	355.0	248	M20	M14	104	16	35.88	35.78	170.0

# KTM SERIES EB OM-2 SPLIT BODY FLOATING BALL VALVES

## IMPERIAL SYSTEM

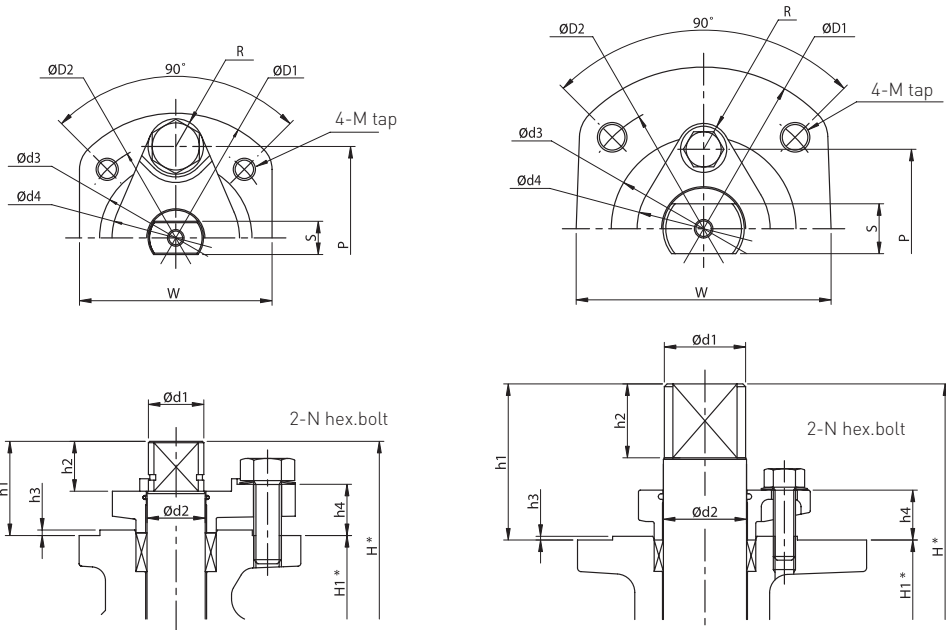

SIZES NPS 1/2 TO NPS 4

SIZES NPS 5 TO NPS 10

\* H and H<sub>1</sub> are from valve center

### TORQUE (In/Lbs)

Size (NPS)	Differential pressure (BarG)					
	0	10	20	30	40	50
1/2	48.7	48.7	48.7	49.6	51.3	58.4
3/4	62.0	62.0	62.8	63.7	67.3	75.2
1	79.7	79.7	83.2	88.5	92.9	106.2
1 1/2	137.2	141.6	150.5	154.9	177.0	221.3
2	194.7	199.1	212.4	239.0	283.2	354.0
2 1/2	354.0	362.9	398.3	451.4	535.4	619.5
3	531.0	610.7	690.3	787.7	885.0	1017.8
4	973.5	1106.3	1283.3	1416.0	1637.3	1858.5
5	1770.0	2035.5	2345.3	2743.5	3097.5	3363.0
6	2743.5	3363.0	3982.5	4779.0	5133.0	5487.0
8	4425.0	6372.0	8496.0	10797.0	12832.5	14160.0

E-seat / PTFE gland packing

### NOTE

Above-mentioned torque table's value does not contain the safety rate.

When you select the actuator, please multiply the safety rate corresponding to the necessity.

### GLAND DIMENSIONS (inch)

Valve size (NPS)		d <sub>1</sub>		d <sub>2</sub>		d <sub>3</sub>		S										W					
Full bore	Reduced bore	Max.	Min.	Max.	Min.	Max.	Min.	d <sub>4</sub>	D <sub>1</sub>	D <sub>2</sub>	h <sub>1</sub>	h <sub>2</sub>	h <sub>3</sub>	h <sub>4</sub>	H	H <sub>1</sub>	M	N	P	R	Max.	Min.	W
1/2	-	0.392	0.388	0.433	0.431	1.181	1.177	1.102	2.165	1.654	0.866	0.433	0.079	0.551	2.323	1.457	M6	M6	1.575	0.236	0.273	0.271	1.68
3/4	-	0.392	0.388	0.433	0.431	1.181	1.177	1.102	2.165	1.654	0.866	0.433	0.079	0.551	2.480	1.614	M6	M6	1.575	0.236	0.273	0.271	1.68
1	-	0.549	0.545	0.591	0.589	1.378	1.374	1.299	2.559	1.969	1.043	0.551	0.079	0.610	2.972	1.929	M6	M8	1.890	0.315	0.312	0.309	1.98
1 1/2	-	0.785	0.781	0.827	0.825	2.165	2.161	1.811	3.543	2.756	1.319	0.709	0.079	0.728	4.035	2.717	M8	M10	2.598	0.394	0.469	0.466	2.76
2	-	0.785	0.781	0.827	0.825	2.165	2.161	1.811	3.543	2.756	1.319	0.709	0.079	0.728	4.429	3.110	M8	M10	2.598	0.394	0.469	0.466	2.76
2 1/2	-	1.061	1.057	1.102	1.100	2.756	2.751	2.598	4.921	4.016	1.988	1.220	0.079	0.866	6.083	4.094	M10	M14	3.386	0.512	0.666	0.663	3.94
3	-	1.061	1.057	1.102	1.100	2.756	2.751	2.598	4.921	4.016	1.988	1.220	0.079	0.866	6.437	4.449	M10	M14	3.386	0.512	0.666	0.663	3.94
4	-	1.337	1.333	1.378	1.376	2.756	2.751	2.598	4.921	4.016	1.988	1.220	0.079	0.866	7.441	5.433	M10	M14	3.386	0.512	0.862	0.859	3.94
5	6	1.730	1.726	1.772	1.769	3.937	3.931	2.835	6.890	5.512	3.327	1.575	0.079	1.063	9.921	6.614	M16	M12	3.386	0.551	1.059	1.056	5.43
6	8	1.730	1.726	1.772	1.769	3.937	3.931	2.835	6.890	5.512	3.327	1.575	0.079	1.063	10.728	7.402	M16	M12	3.386	0.551	1.059	1.056	5.43
8	10	2.085	2.081	2.126	2.123	5.118	5.112	3.543	8.268	6.496	4.213	2.087	0.079	1.299	13.976	9.764	M20	M14	4.094	0.630	1.413	1.409	6.69

# KTM SERIES EB OM-2 SPLIT BODY FLOATING BALL VALVES

## PRESSURE/TEMPERATURE RATING (E-SEAT)

KTM seat ratings: The pressure and temperature limits of various KTM seat materials are available upon request. Below is an example of E-seat (PTFE/PFA copolymer) used for valve sizes from DN 15 - 250 (NPS ½ - 10). Seat ratings for high-temperature valves with Gratiite® seats are identical to ASME body ratings.

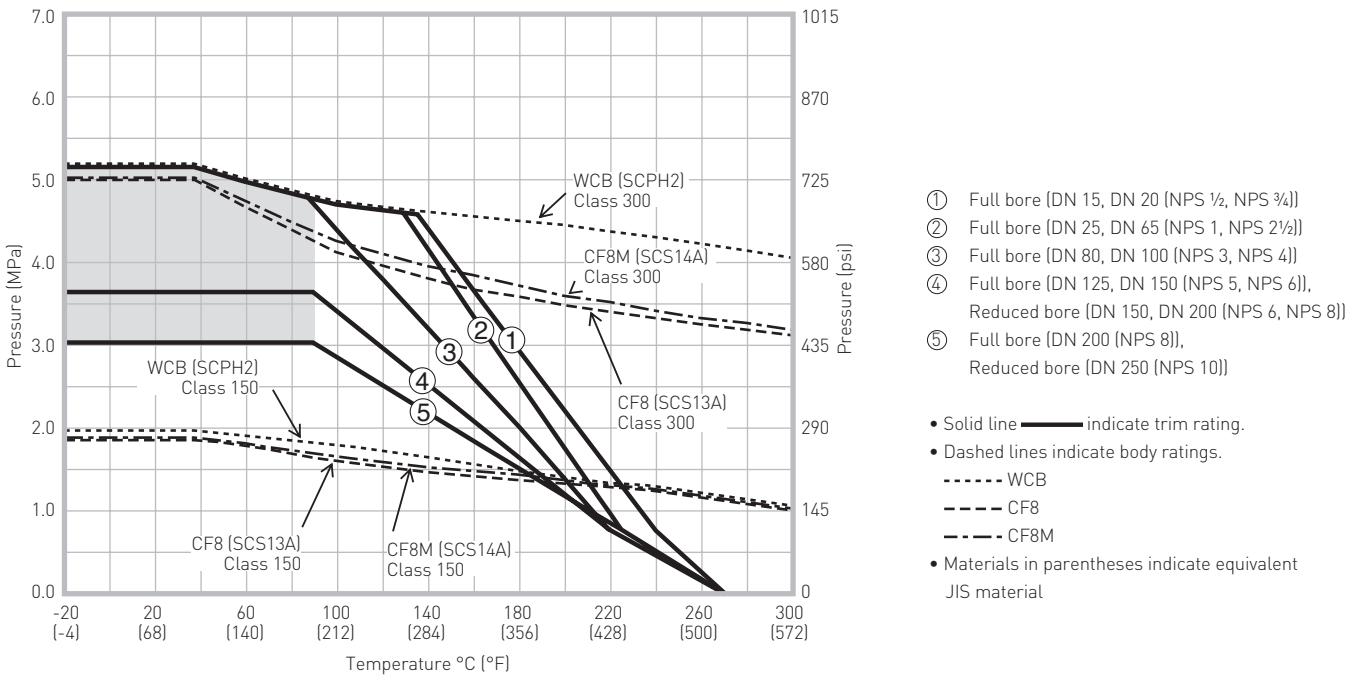

- If continuous service condition is in shaded area for DN 125 - 200 (NPS 5 - 8), trunnion type KTM Ball valve is recommended.
- Maximum pressure / temperature rating  
 ASME Class 150: 1.4 MPa / 120°C (203 psi / 248°F)  
 ASME Class 300: 3.4 MPa / 120°C (493 psi / 248°F)
- E-gasket (PTFE/PFA copolymer) is used for the body gasket in Class 150.  
 Y-gasket (ceramic filled PTFE) is used for the body gasket in Class 300.  
 For temperatures exceeding 230°C (446°F), the Y-gasket in graphite construction must be used for both Class 150 and 300.

## BODY STYLES

OM-2 split body floating ball valves					
Code	Body style	Bore	Connection	Pressure class	Sizes
EB11	Floating type	Full bore	Raised face or smooth finish	ASME 150, JIS 10K	DN 15 - 200 (NPS ½ - 8)
EB12	Floating type	Full bore	Raised face or smooth finish	ASME 300, JIS 20K	DN 15 - 200 (NPS ½ - 8)
EB21	Floating type	Reduced bore	Raised face or smooth finish	ASME 150, JIS 10K	DN 150 - 250 (NPS 6 - 10)
EB22	Floating type	Reduced bore	Raised face or smooth finish	ASME 300, JIS 20K	DN 150 - 250 (NPS 6 - 10)

Neither Emerson, Emerson Automation Solutions, nor any of their affiliated entities assumes responsibility for the selection, use or maintenance of any product. Responsibility for proper selection, use, and maintenance of any product remains solely with the purchaser and end user.

Emerson Automation Solutions, Emerson and the Emerson logo are trademarks and service marks of Emerson Electric Co. All other marks are the property of their respective owners.

The contents of this publication are presented for informational purposes only, and while every effort has been made to ensure their accuracy, they are not to be construed as warranties or guarantees, express or implied, regarding the products or services described herein or their use or applicability. All sales are governed by our terms and conditions, which are available upon request. We reserve the right to modify or improve the designs or specifications of such products at any time without notice.