

KEYSTONE FIGURE 634
SCALING SERVICE CONTROL VALVE

The Figure 634 (F634) is a short body, wafer style control valve designed for the control of liquids, gases and light/medium slurries where scaling is present.



FEATURES

- Robust construction.
- Bi-directional slurry control valve.
- Swing through disc for minimum leakage.
- Extensive size range available.
- Wafer style body.
- Adjustable PTFE gland packing.
- Standardized mounting and drive adaptor connection allowing direct mounting of Keystone actuators and also allows for actuator removal while valve in line.
- Full repairability with replaceable internals that can significantly extend valve life.
- F634 037 features SSEC coating to prevent scaling, prevent against corrosion and improve wear resistance.
- Manufactured under quality system ISO 9001:2015, Certificate No. 10109459.
- Available with PED approval. Cert No. 0038/PED/MUM/2010002/1

GENERAL APPLICATIONS

- Ideally suited for use on green liquor, spent liquor or pregnant liquor service in the alumina industry or other scaling applications.

TECHNICAL DATA

Size range:	DN 40-600
Temperature rating:	Up to 230°C
Pressure rating:	ASME B16.34 Class 150
MaxΔP:	Refer to chart
Standard flange drilling:	ASME B16.5 Class 150 F.F



KEYSTONE FIGURE 634

SCALING SERVICE CONTROL VALVE

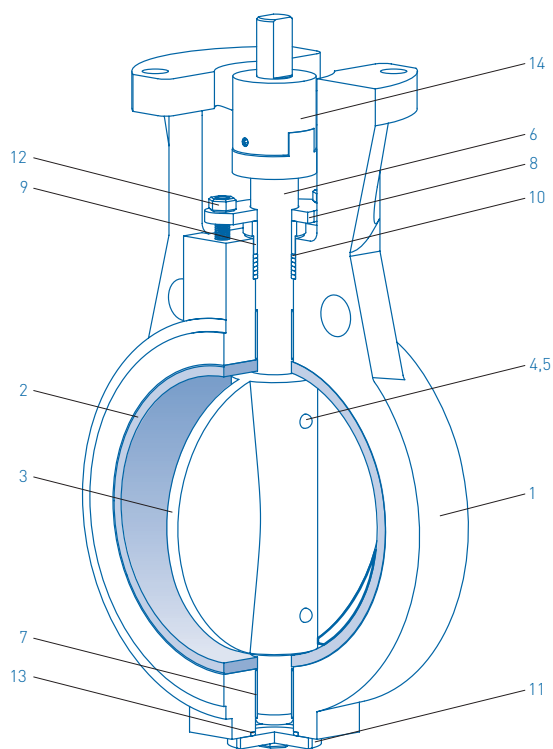

OPTIONS

- Keystone Figure 89U hard anodized, rack and pinion style aluminum pneumatic actuators, double acting and spring return options available.
- Biffi Morin "S" Series, scotch yoke style, stainless steel pneumatic actuators, double acting and spring return options available.
- Biffi Morin "B" Series, scotch yoke style, ductile iron pneumatic actuators with stainless steel cylinder barrel material as standard, double acting and spring return options available.
- Biffi ICON3000 electric actuators
- Keystone Figure 427 manual gear operators
- Solenoids, positioners and position monitoring devices are readily available - consult your local Emerson representative

PARTS LIST

No.	Description	Material	Specification
1	Body	S.G. Iron	AS 1831 500-7
		Carbon steel	ASTM A216 WCB
2	Liner	Carbon steel* / SSEC	Commercial
3	Disc	S.G. Iron* / SSEC	AS 1831 500-7
4	Disc pin	Spring alloy steel	Commercial
5	Disc drive screw	431 S/S / Carbon steel	ASTM A276 431 Condition A / AS 3678 Grade 250
6	Shaft	431 S/S* / SSEC	ASTM A276 431 Condition A
7	Bearings	PTFE / glass	Commercial
8	Gland plate	Carbon steel	AS 3678 Grade 250
9	Gland collar	431 S/S	ASTM A276 431 Condition A
10	Gland packing	PTFE Braid	PTFE
11	End cover	Carbon steel	AS 3678 Grade 250
12	Fasteners	Alloy steel / 316 S/S	Commercial
13	O-ring	FKM	Commercial
14	Drive dog	431 S/S	ASTM A276 431 Condition A

NOTES:

* Carbon steel bodies are available as an option.

KEYSTONE FIGURE 634

SCALING SERVICE CONTROL VALVE

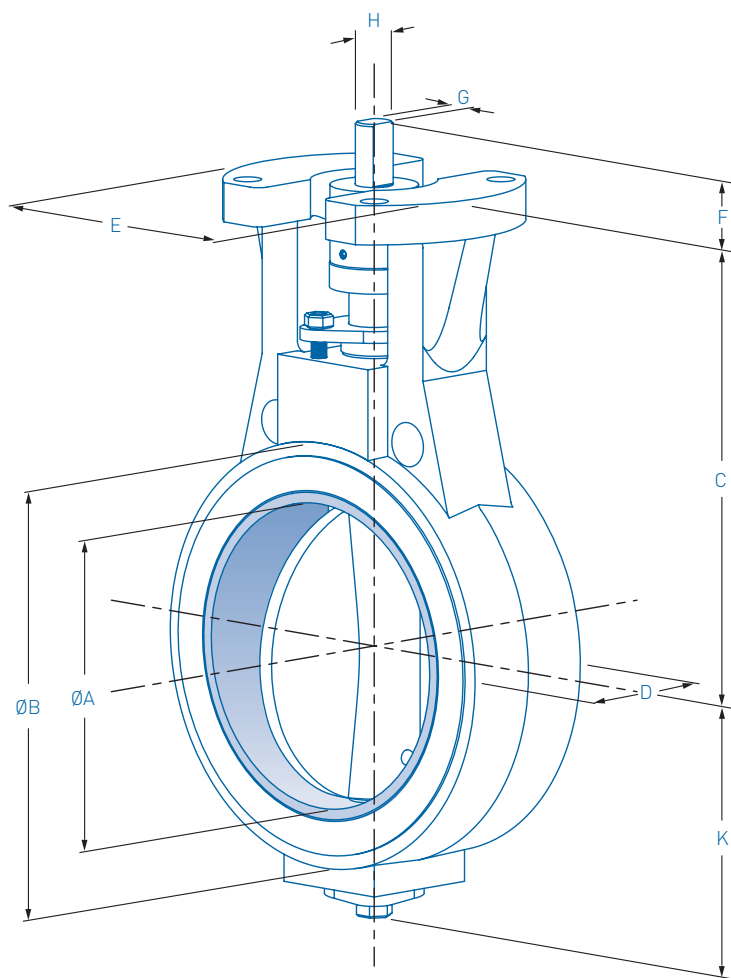

PRESSURE DIFFERENTIALS TABLE

Valve size DN	Valve closed at 0°	Valve open at 60°
40	1960	1960
50	1960	1960
65	1960	1960
80	1960	1960
100	1960	1960
150	1960	700
200	1960	570
250	1960	525
300	1960	315
350	1960	300
400	1600	220
450	1600	215
500	1350	175
600	1250	165

NOTE:

Figures shown are allowable pressure differentials kPa at 65°C.

DIMENSIONS (mm)

Valve size DN	Stem code	Shaft dia		Stem conn.								Top plate			Mass kg	K _v at full open	
		inches	ØA	ØB	C	D	E	F	K	Q	H x G / ØH	Keyway	PCD mm	No. holes			Hole dia. mm
40	BAD	3/8	40	80	127	55	110	31	40	-	3/4 x 1/2	-	83	4	11	5	65
50	BAD	3/8	50	100	162	64	110	31	66	-	3/4 x 1/2	-	83	4	11	6	72
65	BAD	3/8	63	117	167	64	110	31	75	-	3/4 x 1/2	-	83	4	11	7	89
80	BAD	3/4	76	133	196	70	115	31	85	30	3/4 x 1/2	-	83	4	11	10	163
100	BAD	1	101	157	208	76	140	31	108	67	3/4 x 1/2	-	83	4	11	13	348
150	CAF	1	154	216	238	76	152	51	132	135	1 1/8	1/4 x 1/4	127	4	14	18	1094
200	CAF	1 1/4	203	270	295	83	182	51	174	185	1 1/8	1/4 x 1/4	127	4	14	31	2375
250	CAK	1 1/2	254	330	329	102	182	108	213	232	2 1/4	1/2 x 3/8	127	4	14	48	3752
300	CAK	1 1/2	305	400	374	102	182	108	258	287	2 1/4	1/2 x 3/8	127	4	14	70	5745
350	CAK	1 3/4	336	444	390	111	182	108	275	317	2 1/4	1/2 x 3/8	127	4	14	100	7305
400	CAK	1 3/4	387	495	427	111	182	108	312	371	2 1/4	1/2 x 3/8	127	4	14	120	9930
450	DAK	2	438	540	457	127	200	108	344	419	2 1/4	1/2 x 3/8	165	4	21	145	12696
500	DAK	2 1/4	489	595	492	133	220	108	381	470	2 1/4	1/2 x 3/8	165	4	21	190	15533
600	DAK	2 1/2	582	708	569	158	250	108	454	560	2 1/4	1/2 x 3/8	165	4	21	225	23123

NOTES:

Q = The chordal dimension at face of valve for disc clearance into pipe or flange.

H = The dimension of the stem connection.

G = The dimension across the stem flats.

K_v = The flow rate of water in m³/hr that will pass through a valve with a pressure drop of 1 bar (100 kPa) at 20°C

C_v = 1.155 K_v

Dimensions are nominal ± 1mm.

KEYSTONE FIGURE 634

SCALING SERVICE CONTROL VALVE

SPECIAL COATINGS TO ENHANCE VALVE SERVICE LIFE

Standard Coating

SSEC: Synergistic Surface Enhancement Coating

Well suited for use in applications where corrosive media or abrasion is a problem, SSEC is ideal for applications with sticky, viscous media, scaling/plating or where galling is a problem. The low coefficient of friction prevents scale adhesion to the valve internal components thus extending valve service life. SSEC is a synergistic coating that combines the advantages of anodizing, plating or thermal spraying with the controlled infusion of polymers, dry lubricants and other materials to provide an entirely new composite with improved properties to the base metal. This coating will work on most metal surfaces and creates a harder-than-steel surface, excellent release (non-stick) properties, protects against wear, corrosion and chemical attack and provides permanent lubricity and a superior resistance to static build up of material.

Engineering Data

SSEC

- Hardness/wear and abrasion resistance – Up to Rc 68. Equilibrium Wear Rate (EWR) using Taber abrasion testing methods (CS-10 wheel): 2.0 – 4.0 mg per 1,000 cycles.
- Coefficient of friction – As low as 0.09. Eliminates “stick-slip” problems. Often improves micro finish of a disc or liner.
- Temperatures – Operating range of -157° to 288°C (-250° to 550°F). Coating will survive temperatures of 760°C (1400°F), but all lubricant will dissipate above 426°C (800°F).
- Corrosion resistance – SSEC will survive 500 hours in ASTM B-117 salt spray. Selected types can withstand over 1,000 hours. Coating thickness will affect corrosion resistance. Special types can survive in Hydrogen Sulfide encountered in oil field applications.
- Thickness of SSEC – Surface build-up from 0.005mm to 0.076mm (0.0002” to 0.003”), control tolerances as low as ±0.005mm (±0.0002”).
- Applications – Steel, stainless, copper, brass, bronze, titanium and aluminium are the basic metals that can be enhanced by using SSEC. Abrasion resistance, lubricity, corrosion resistance and anti-stick plus galling can be obtained through use of SSEC.

NOTE:

Emerson does not recommend any coating be used as an attempt to reduce metallurgy of the base material required for the application.

KEYSTONE FIGURE 634

SCALING SERVICE CONTROL VALVE

ANTICIPATED SEATING AND UNSEATING TORQUE VALUES – Nm

Valve size DN	Shut off pressure kPa									
	Normal service					Severe service				
	0	350	700	1000	1400	0	350	700	1000	1400
40	20	21	22	23	24	30	31	32	33	34
50	25	26	27	28	29	37	38	40	41	42
65	30	32	33	34	35	45	46	47	49	50
80	36	38	41	43	45	54	56	59	61	63
100	54	58	61	64	68	81	85	88	92	95
150	102	113	124	136	147	152	164	175	186	198
200	169	192	215	237	260	254	277	299	322	345
250	260	294	328	362	395	390	424	458	492	525
300	350	407	463	520	576	525	582	638	695	751
350	486	576	667	757	847	729	819	910	1000	1090
400	621	757	893	1028	1164	932	1068	1203	1339	1475
450	780	983	1186	1390	1593	1170	1373	1576	1780	1977
500	960	1243	1525	1808	2090	1441	1723	2006	2288	2570
600	1152	1429	1754	2079	2466	1701	2033	2387	2746	3085

GUIDELINES

Operating torques for these valves are generated from bearing/packing friction, component weight, hydro-dynamic and contaminant forces, etc.

There are no hard and fast rules which can accurately and practically determine the sum total of all these forces. (Refer Emerson Valve Manual for further information).

The following guidelines are considered to be conservative and can confidently be used for routine duties. If you have any doubts consult a Emerson sales representative.

DUTY DEFINITIONS

Normal

- Liquid service to 3 m/s
- Gases – Non-abrasive
 - Natural gas
 - Hot air
 - Exhausts-flues
 - Coke ovens gas
 - Oxygen-nitrogen, etc
- Light-medium abrasion
 - Pneumatic conveying
 - 3-4000 fpm – 20 m/s
 - Crystallising liquors low velocity
 - 5-10% fine solids low velocity

Severe

- Medium abrasion
 - Pneumatic conveying dense phase, average velocities.
 - Magnetite slurries
 - Cement slurries
 - Bauxite slurries
 - Ore slurries

K_v VALUES/FLOW RATE CO-EFFICIENTS

Size DN	Angle of disc opening									
	0°	10°	20°	30°	40°	50°	60°	70°	80°	90°
40	2	2	3	8	11	23	36	50	64	65
50	4	5	7	9	13	26	40	56	71	72
65	6	7	10	16	21	36	49	69	87	89
80	7	10	18	33	55	77	92	127	162	163
100	9	12	19	42	62	126	195	272	345	348
150	12	28	64	132	197	394	613	854	1084	1094
200	16	46	131	285	428	855	1331	1855	2353	2375
250	21	62	206	450	675	1351	2103	2929	3718	3752
300	26	108	316	690	1035	2069	3220	4485	5693	5745
350	38	141	402	877	1316	2632	4094	5703	7239	7305
400	43	185	547	1195	1784	3576	5565	7752	9840	9930
450	49	230	699	1524	2287	4575	7116	9912	12581	12696
500	65	291	855	1866	2798	5597	8706	12127	15392	15533
600	70	415	1273	2777	4165	8332	12960	18052	22913	23123

NOTE:

This data is based on calculated theoretical figures.

K_v = The volume of water in m³/hr that will pass through a given valve opening at a pressure drop of 1 bar (100kPa) at 20°C.

C_v = 1.155K_v

KEYSTONE FIGURE 634

SCALING SERVICE CONTROL VALVE

TYPICAL SPECIFYING SEQUENCE

100	F634	037	ASME 150			
Valve size	Figure number	Trim code	End connections			
Trim code	Body	Disc	Shaft	Seat	Bearings	Packing
037	SG Iron / carbon steel	S.G. Iron / SSEC	431 S/S / SSEC	Carbon steel / SSEC	PTFE / Glass	PTFE

NOTE:

Carbon Steel bodies are available as an option.
 SSEC = Synergistic Surface Enhancement Coating

© 2010, 2020 Emerson Electric Co. All rights reserved 07/20. Keystone is a mark owned by one of the companies in the Emerson Automation Solutions business unit of Emerson Electric Co. The Emerson logo is a trademark and service mark of Emerson Electric Co. All other marks are the property of their prospective owners.

The contents of this publication are presented for informational purposes only, and while every effort has been made to ensure their accuracy, they are not to be construed as warranties or guarantees, express or implied, regarding the products or services described herein or their use or applicability. All sales are governed by our terms and conditions, which are available upon request. We reserve the right to modify or improve the designs or specifications of such products at any time without notice.

Emerson Electric Co. does not assume responsibility for the selection, use or maintenance of any product. Responsibility for proper selection, use and maintenance of any Emerson Electric Co. product remains solely with the purchaser.

Emerson.com/FinalControl