

# NELSON™

## EXPTC125 POWER TEE SPLICE CONNECTION KIT

## INSTALLATION INSTRUCTIONS



### DESCRIPTION

The EXPTC125 Tee Splice Connection Kit is designed to connect three heater cables in a tee splice configuration and with the removable plug can also connect the heating cables to customer supplied power wiring. This kit is designed for use with all wattages of CLT-J(ordinary locations), CLT-JT(ordinary locations), LT-J, LT-JT, UT-1, QLT-J, HLT-J and XLT-J heating cable constructions. The EXPTC125 is rated IP66/NEMA 4X. The EXPTC125 connection kit may be used to connect multiple heater segments, connect different wattage cables together or to provide access to serviceable equipment.

These instructions are to be used together with the installation and maintenance instructions for self-regulating heater cable (GA-1765).

### KIT CONTENTS

QTY	ITEM	DESCRIPTION
1	1	ENCLOSURE WITH TERMINAL BLOCKS
3	2	POWER TERMINATION
3	3	END TERMINATION
1	4	SILICONE ADHESIVE
1	5	ENCLOSURE ADAPTER
1	6	STANDOFF
1	7	LOCKNUT
3	8	GREEN/YELLOW TUBE
1	9	CABLE CLAMP
1	10	CABLE TIE (not shown)
1	11	STOPPING PLUG
6	12	GUIDE TUBES (not shown)
1	13	PRODUCT LABEL (not shown)

### INSTALLATION ACCESSORIES

- Pipe Clamp – PC03, PC12 or PC20 (included)
- Fiberglass Tape – GT6 or GT60

### OPTIONAL INSTALLATION MATERIAL

- HC-SPA Small Pipe Adapter – For 25 mm (1.0") diameter pipe and below.

### RECOMMENDED TOOLS

- Utility Knife
- Wire Cutters
- Adjustable Wrench (52mm [2.1"] size)
- Needle Nose Pliers
- Small Flat Blade Screwdriver
- Large Slotted Screwdriver
- Allen wrench (10mm [3/8"] size)

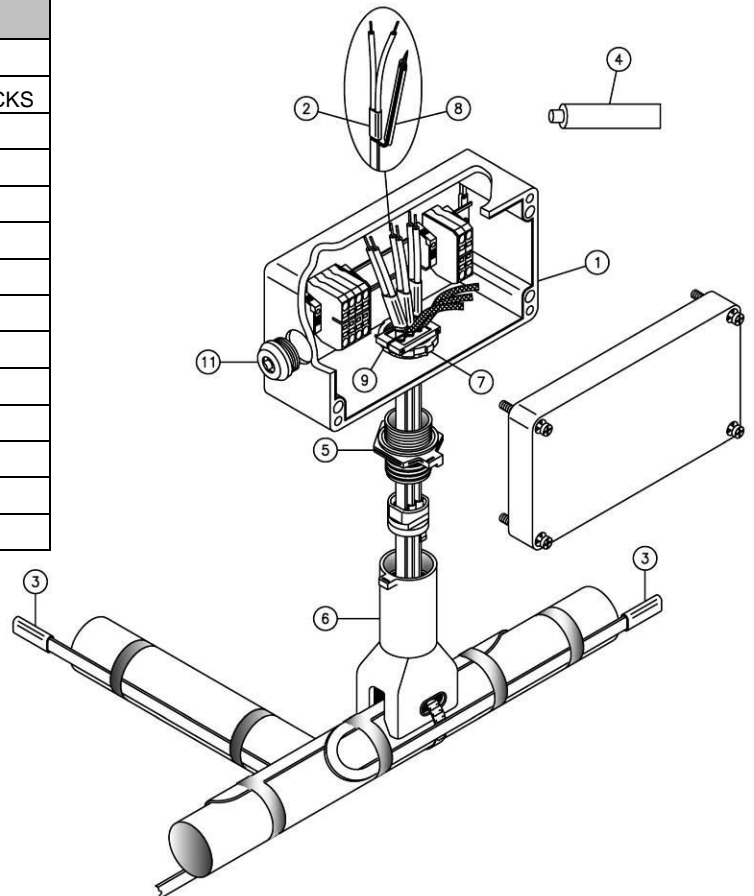

#### STANDOFF POSITIONING

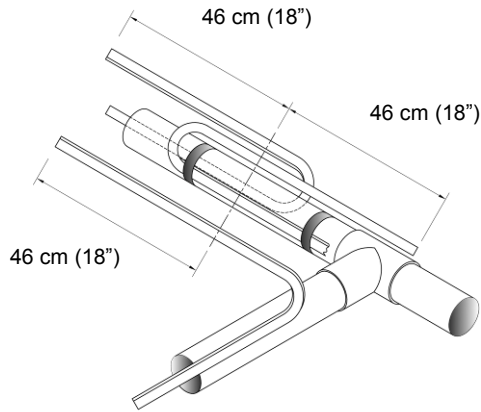

- Mark pipe where standoff will be mounted.
- Allow approximately 46 cm (18") of each heating cable for installation.
- Heating cable may be cut at a 45° angle for easier penetration.

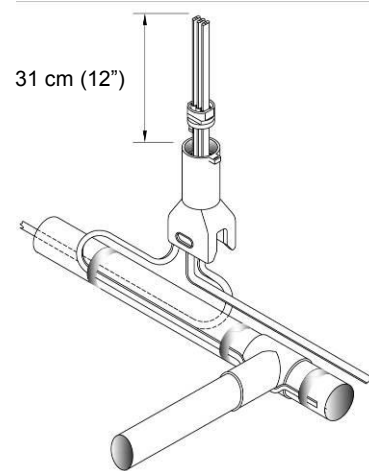

- Insert cable retainer assembled with cable grommet into standoff and clip into place.
- Insert heating cables through standoff allowing approximately 31 cm (12") of cable for terminations.
- Use cable lubricant if necessary.
- Proceed to Heating Cable Terminations.

#### STEP 1

#### STEP 2

#### CABLE CONSTRUCTION DETAILS

LT / UT-1 SELF-REGULATING CABLE    HLT / QLT / XLT SELF-REGULATING CABLE    CLT SELF-REGULATING CABLE

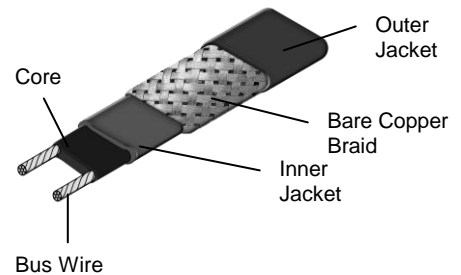
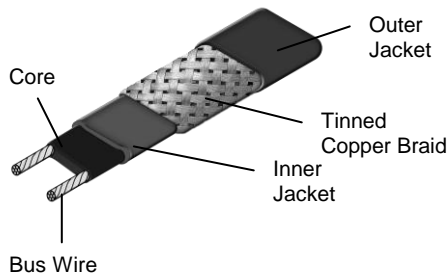
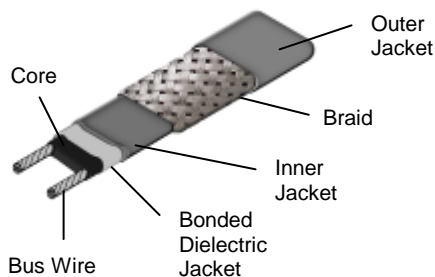

#### HEATING CABLE PREPARATION

- 1**
- Lightly cut around the cable outer jacket and up the center.
  - Bend cable to break outer jacket.

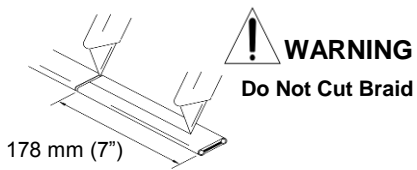

- 6**
- Lightly cut around the cable inner jacket.

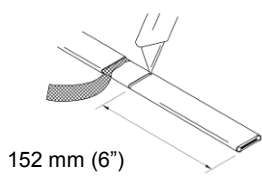

- 2**
- Remove outer jacket from heating cable.

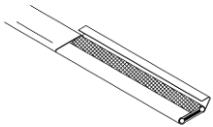

- 7**
- Cut up the middle of the inner jacket.
  - Bend cable to break inner jacket and remove.

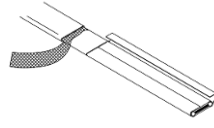

- 3**
- Push braid back to create a bulge.

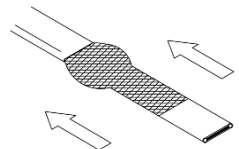

- 8**
- Shave the core material from the outside of each bus wire.

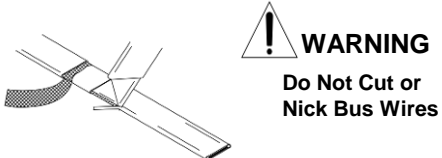

- 4**
- At the bulge, separate the braid to make an opening.

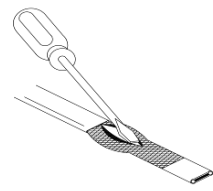

- 9**
- Notch core material approximately 6 mm (1/4 inch) for the end of the heating cable.



- 5**
- Bend heating cable at opening and pull the cable through.

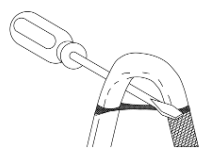

- 10**
- Peel both bus wires from core material.

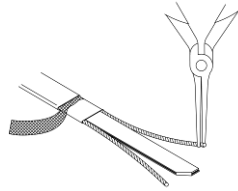

#### HEATING CABLE PREPARATION

- 11**
- Lightly score core material and snap off at base of bus wires.

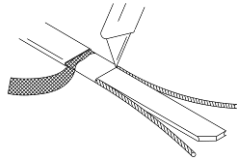

- 12**
- Trim away any frayed or damaged bus wire ends.
  - Pull braid tight to form a pigtail.

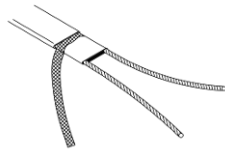

#### POWER TERMINATION INSTALLATION

- 1**
- Insert guide tubes into power termination, if required. Note: XLT cable will need to be installed without the assistance of guide tubes.

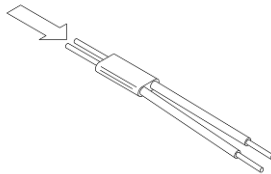

- 2**
- Make sure that all strands are inserted through tubes.

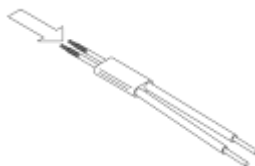

- 3**
- Pinch power termination body and fill void with silicone adhesive. The silicone will set up in approximately 30 minutes with a complete cure after 24 hours.

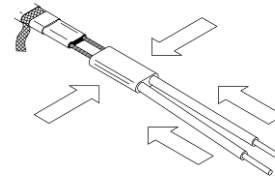

**! WARNING**

- Be sure that bus wires do not bunch or cross-over

- 4**
- Push power termination to overlap jacket.
  - Remove guide tubes if used previously.

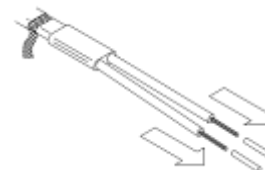

### POWER TERMINATION INSTALLATION

- 5**
- Slide green/yellow tubing over braid.
  - Trim bus wires and braid as necessary.



**! WARNING**

- Do not megger or hipot until silicone completely cured.
- Braid must be kept from bus wires or shorting may occur.

### END TERMINATION INSTALLATION

- 1**
- Lightly cut around the cable outer jacket and up the center.
  - Bend cable to break outer jacket.

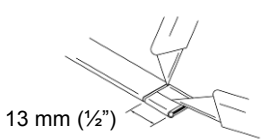

- 5**
- Pinch end termination body and fill void with silicone adhesive.

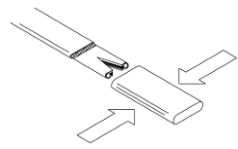

- 2**
- Remove outer jacket from heating cable.

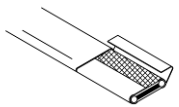

- 6**
- Push termination firmly onto heating cable.

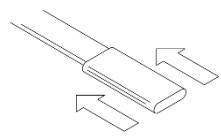

- 3**
- Trim excess braid up to the heating cable jackets.

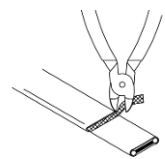

Note: The end seal is limited to exposure temperatures of 191°C (375°F). The HEC100 or HEL100 kits can be used to terminate the cable off the pipe in higher exposure temperature situations

- 4**
- Make a diagonal cut between bus wires.

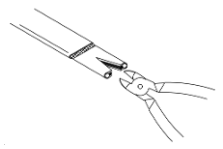

**FINAL ASSEMBLY**

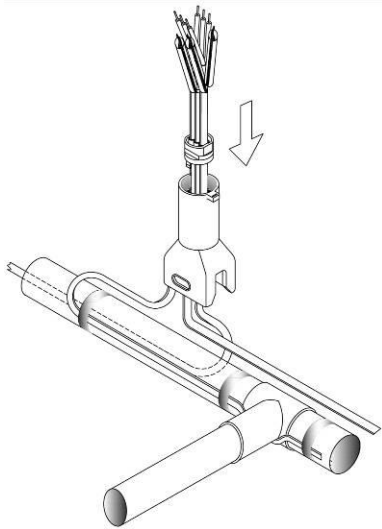

- Pull excess heating cable back through standoff.

**STEP 3**

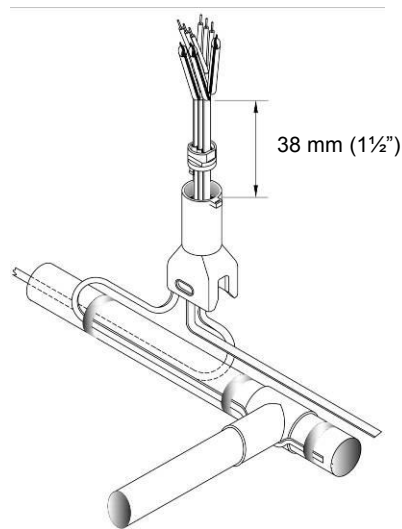

- Allow 3.81 cm (1 1/2") of each heating cable to remain above top of standoff body.

**STEP 4**

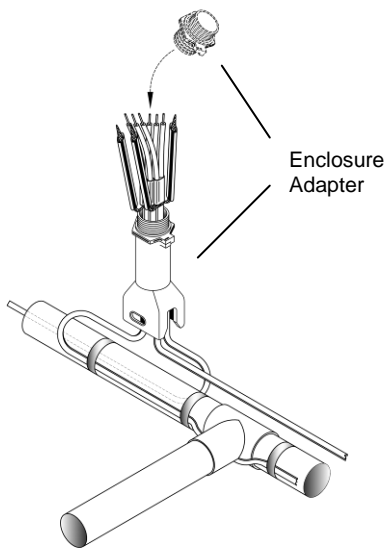

- Carefully slide enclosure adapter over cable terminations.
- Screw enclosure adapter into standoff until fully seated at positive stop.

**STEP 5**

Note: For pipes 25mm (1") and below, install HC\_SPA (purchased separately) between standoff and pipe.

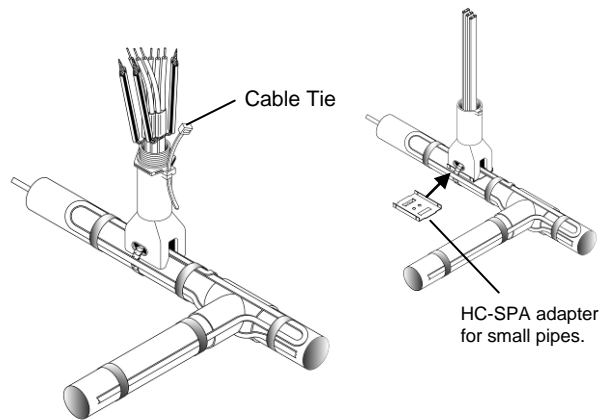

- Mount standoff securely to pipe.
- Insert supplied cable tie through slot provided to prevent possible rotation of enclosure.

**STEP 6**

# NELSON™ EXPTC125 POWER TEE SPLICE CONNECTION KIT

## INSTALLATION INSTRUCTIONS

### FINAL ASSEMBLY

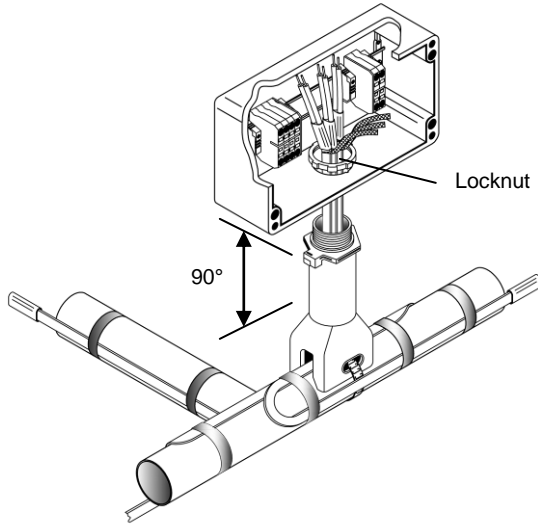

- Install enclosure and secure to enclosure adapter with supplied locknut.
- Do not over tighten locknut
- Enclosure may be rotated in 90° increments to match installation requirements.

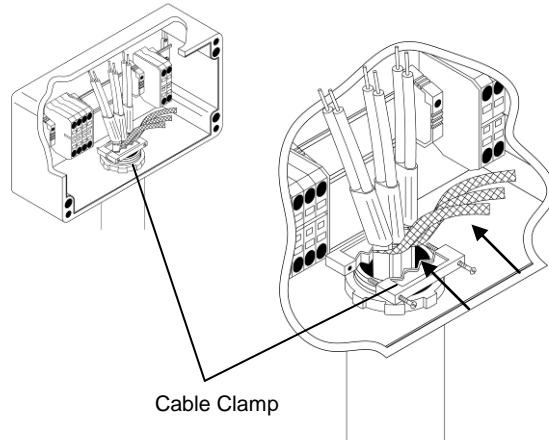

- Install cable clamp over heating cables at top of enclosure adapter.
- Tighten cable clamp with supplied screws.
- Do not over tighten.

### STEP 7

### STEP 8

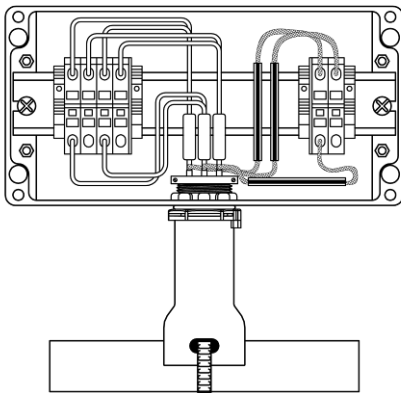

- Terminate bus wires and ground braids to terminal block.
- Install enclosure cover.

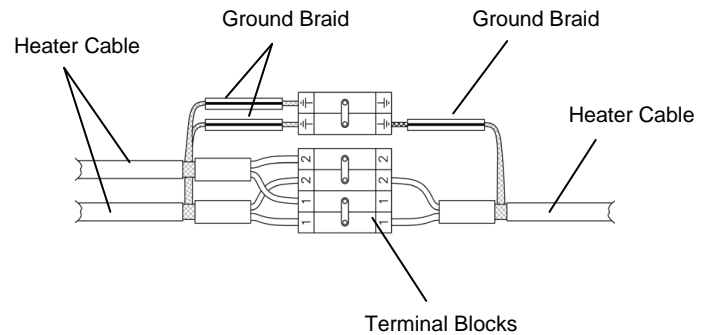

- Maximum steady-state current may not exceed 18 amps. 25 amps for XLT cable.
- Verify that all connections are properly installed and secure.

### STEP 9

### ELECTRICAL WIRING

# NELSON™

## EXPTC125 POWER TEE SPLICE CONNECTION KIT

## INSTALLATION INSTRUCTIONS

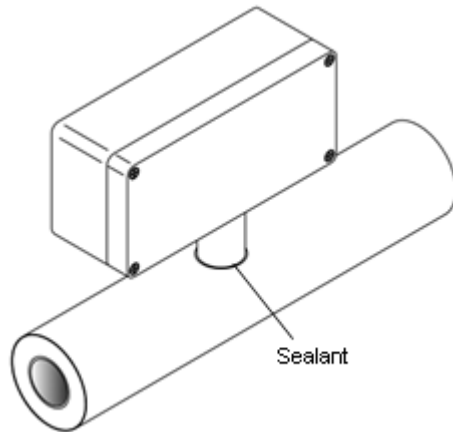

- Install thermal insulation and protective lagging.
- Apply sealant around standoff penetration to prevent moisture entry.
- Leave installation instructions with end user for future maintenance and/or trouble shooting.
- Fill in the blank fields on the label located on the cover of the junction box as follows:  
CIR. NO. – Electrical circuit heating cable connected too.  
CAT. NO. – Type of heating cable used  
Volts – Operating voltage of heating cable – Max 277VAC  
Amps – Operating current of heating cable – Max 18A continuous current. 25A for XLT Cable

### STEP 10

### OPTIONAL CUSTOMER SUPPLIED POWER CONNECTION WIRING

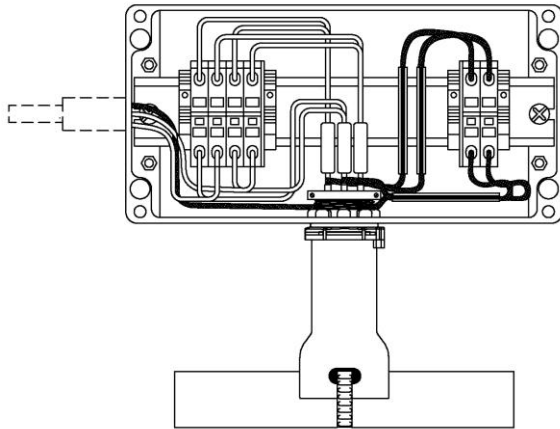

- Remove stopping plug.
- Install power gland as shown.
- Terminate power and ground wires to terminal block.
- Install enclosure cover.

### STEP 11

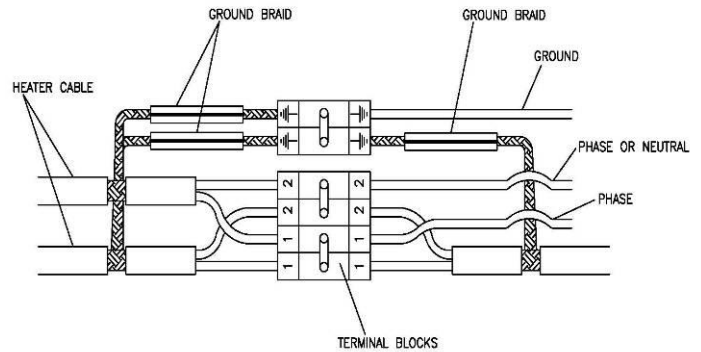

- Heating cable installations require incoming power wiring to be rated for 105°C operation.
- Maximum steady-state current may not exceed 18 amps. 25 amps for XLT cable.
- Verify that all connections are properly installed and secure.

### ELECTRICAL WIRING



**GENERAL CONDITIONS OF SAFE USE**

- To prevent electrical arcing and fire hazard, all cable connections and electrical wiring connections should be sealed against moisture. This includes the use of proper cable sealing kits and the moisture proofing of all wire connections.
- The metal sheath/braid of the heating cable must be connected to a suitable ground path before electrical power is connected to this equipment.
- Isolate electrical power supply before opening or removing the enclosure cover.
- The enclosure cover must be secured with all screws provided to maintain the environmental ratings.
- The main components used in this connection system may present a hazard from static electricity. Only surface cleaning with a damp cloth is acceptable.
- Routine maintenance is required to maintain compliance with health and safety legislation:
  - Check that the cover gasket is in place and not damaged each time the enclosure is closed.
  - Check that all cover screws are in place and secure each time the enclosure is closed.
  - Check the security of all cable entries on a routine basis.
  - Check that all electrical connections are tight and secure on a routine basis.
  - Check for physical damage and replace as required.
- This connection system is designed for use in areas subject to normal industrial levels of vibration. They are not designed for use in areas subject to intentional or extreme conditions of vibration.
- Measures shall be taken to avoid accumulation of dust inside the standoff. This could result in unacceptable temperature rises violating the certification of the equipment.

**APPROVALS**

**NEC®; NFPA 70: National Electrical Code®, International Electrical Code Series**

**IEEE Std 515™-2011 Standard for the Testing, Design, Installation, and Maintenance of Electrical Resistance Heat Tracing for Industrial Applications**



Class I, Division 2, Groups BCD  
Class II, Groups EFG; (Canada Only)  
Class III; (Canada Only)  
Encl. Type 4X, Temp. Code T6 – T3;  
Usages -G, -W  
Class 1 Zone 1; Ex e II; T3 to T6  
CSA . II . 2406879



Class I, Division 2, Groups BCD  
Class II, Groups EFG; Class III  
Encl. Type 4X, IP66, Temp. Code T\*;  
Class 1 Zone 1; AEx e IIC; T\*  
-40°C ≤ Tamb ≤ 55°C  
\* For temperature code see heating cable  
or design information



Class I, Division 2, Groups ABCD;  
Class II, Division 2 Groups FG;  
Class III;  
Encl. Type 4X, Temp. Code T\*;  
UL File E49805  
\* For temperature code see heating cable  
or design information

**Compliance with the Essential Health and Safety Requirements has been assured by compliance with:**

**ATEX:** EN 60079-0:2012+A11:2013, EN 60079-30-1:2007, EN 60079-7:2007, EN 60079-31:2014

**IECEx:** IEC 60079-0:2011, IEC 60079-30-1:2007, IEC 60079-7:2006, IEC 60079-31:2013

**CE** 0344  
**KEMA 07ATEX0124**



**IECEx KEM 07.0041**

Ex e IIC T6...T5\* Gb for LT / UT-1 Series  
Ex e IIC T3 Gb for HLT / QLT / XLT Series  
Ex tb IIIC T80°C...T95°C\* Db for LT / UT-1 Series  
Ex tb IIIC T195°C Db for HLT / QLT / XLT Series  
-40°C ≤ Tamb ≤ 55°C  
IP66

\* For temperature code see heating cable or design information

Nelson Heat Tracing Systems products are supplied with a limited warranty. Complete Terms and Conditions may be found on Nelson's website at [www.nelsonheaters.com](http://www.nelsonheaters.com). Nelson is a trademark of the Appleton Group LLC (Heating Cable Systems), 2 Connecticut South Dr, East Granby, CT, 06026. A division of Emerson Automation Solutions.